

# Polymer PTC Resettable Fuse: KLM Series

## SMD Low Resistance Type



### ■ Features

1. RoHS & Halogen-Free (HF) compliant
2. EIA size: 0603, 0805, 1206, 1210, 1812
3. Hold current ratings from 0.5A to 7.5A
4. Vmax: 6V, 12V
5. Small footprint
6. Ultra low resistance
7. Fast time to trip
8. Operating & storage temperature range: -40~+85°C
9. Agency Approval: UL / cUL / TUV

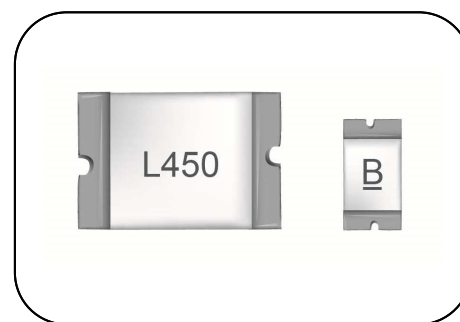

### ■ Recommended Applications

1. USB, HDMI, IEEE 1394 interface
2. PC, Motherboard, NB, Tablet
3. Protection for lithium ion battery of cell phone
4. Digital cameras
5. Telecommunication
6. Consumer device

### ■ Part Number Code

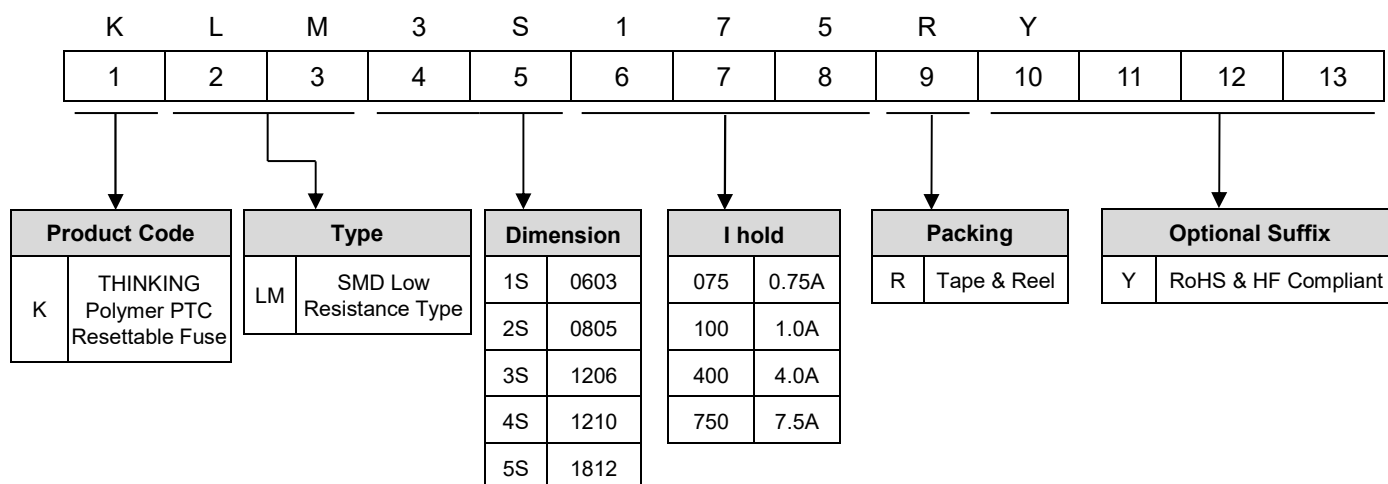

# Polymer PTC Resettable Fuse: KLM Series

## SMD Low Resistance Type



### ■ Structure & Dimensions

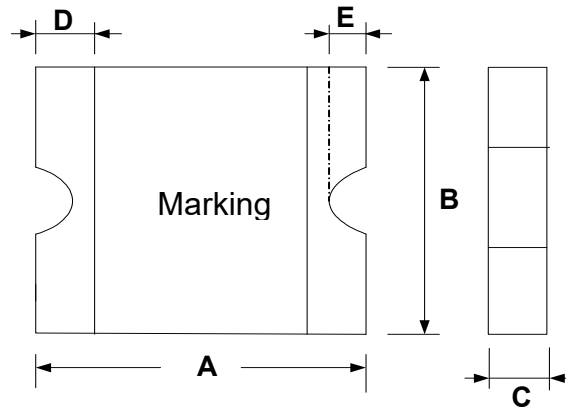

(Unit: mm)

Part No.		A		B		C		D		E	
		(Min.)	(Max.)	(Min.)	(Max.)	(Min.)	(Max.)	(Min.)	(Max.)	(Min.)	(Max.)
KLM1S050	KLM1S050-8	1.40	1.80	0.60	1.00	0.3	0.65	0.125	0.50	0.05	0.40
KLM1S075	KLM1S075-8					0.3	0.65				
KLM1S100	KLM1S100-8					0.3	0.65				
KLM1S150	KLM1S150-8					0.5	0.8				
KLM1S175	KLM1S175-8					0.5	0.8				
KLM1S200						0.5	0.8				
KLM2S075	KLM2S075-12	2.00	2.20	1.20	1.50	0.4	0.7	0.150	0.55	0.05	0.45
KLM2S110	KLM2S110-12					0.4	0.7				
KLM2S150	KLM2S150-12					0.5	0.88				
KLM2S175	KLM2S175-12					0.5	0.88				
KLM2S200						0.5	0.88				
KLM2S260						0.5	0.88				
KLM2S300						0.5	1.2				
KLM2S350						0.6	1.2				
KLM2S400						0.6	1.2				
KLM3S075	KLM3S075-12	3.00	3.50	1.50	1.80	0.4	0.7	0.125	0.75	0.08	0.45
KLM3S110	KLM3S110-12					0.4	0.7				
KLM3S150	KLM3S150-12					0.4	0.7				
KLM3S175	KLM3S175-12					0.6	1.2				
KLM3S200	KLM3S200-12					0.6	1.2				
KLM3S260	KLM3S260-12					0.6	1.2				
KLM3S300	KLM3S300-12					0.6	1.2				
KLM3S350	KLM3S350-12					0.6	1.2				
KLM3S380	KLM3S380-12					0.6	1.2				

# Polymer PTC Resettable Fuse: KLM Series

## SMD Low Resistance Type



### ■ Structure & Dimensions

(Unit: mm)

Part No.		A		B		C		D		E	
		(Min.)	(Max.)	(Min.)	(Max.)	(Min.)	(Max.)	(Min.)	(Max.)	(Min.)	(Max.)
KLM3S400	KLM3S400-12	3.00	3.50	1.50	1.80	0.6	1.2	0.125	0.75	0.08	0.45
KLM3S450	KLM3S450-12					0.6	1.2				
KLM3S500	KLM3S500-12					0.6	1.2				
KLM3S550						0.6	1.2				
KLM3S600						0.6	1.2				
KLM4S175	KLM4S175-12	3.00	3.43	2.35	2.80	0.4	0.7	0.125	0.75	0.08	0.50
KLM4S200	KLM4S200-12					0.4	0.7				
KLM4S260	KLM4S260-12					0.4	0.7				
KLM4S300	KLM4S300-12					0.6	1.2				
KLM4S350	KLM4S350-12					0.6	1.2				
KLM4S380	KLM4S380-12					0.6	1.2				
KLM4S400	KLM4S400-12					0.6	1.2				
KLM4S450	KLM4S450-12					0.6	1.2				
KLM4S500	KLM4S500-12					0.6	1.2				
KLM4S550						0.6	1.2				
KLM4S600						0.6	1.2				
KLM4S650						0.6	1.2				
KLM4S700						0.6	1.2				
KLM4S750						0.8	1.4				
KLM5S190	KLM5S190-12	4.37	4.73	3.07	3.41	0.4	0.7	0.20	1.20	0.15	0.65
KLM5S260	KLM5S260-12					0.4	0.7				
KLM5S270	KLM5S270-12					0.4	0.7				
KLM5S300	KLM5S300-12					0.4	0.7				
KLM5S350	KLM5S350-12					0.4	0.7				
KLM5S370	KLM5S370-12					0.4	0.7				
KLM5S400	KLM5S400-12					0.4	0.7				
KLM5S450	KLM5S450-12					0.6	1.2				
KLM5S500	KLM5S500-12					0.6	1.2				
KLM5S550						0.6	1.2				
KLM5S600						0.6	1.2				
KLM5S650						0.6	1.2				
KLM5S700						0.6	1.2				
KLM5S750						0.8	1.4				

# Polymer PTC Resettable Fuse: KLM Series

## SMD Low Resistance Type



### Electrical Characteristics at 23°C

Part No.	Marking	Vmax.	Imax.	Ihold	Itrip	Pd (Max.)	Maximum Time to Trip		Resistance		Safety Approvals	
		(V <sub>dc</sub> )	(A)	(A)	(A)	(W)	Current	Time	Initial Ri	Post Trip R1	UL/cUL	TUV
							(A)	(Sec.)	Min. (Ω)	Max(Ω)		
KLM1S050	a	6	50	0.5	1	0.6	8	0.1	0.07	0.35	√	√
KLM1S050-8	a	8	50	0.5	1	0.6	8	0.1	0.07	0.35	√	
KLM1S075	b	6	50	0.75	1.5	0.6	8	0.2	0.05	0.25	√	√
KLM1S075-8	b	8	50	0.75	1.5	0.6	8	0.2	0.05	0.25	√	
KLM1S100	c	6	50	1	1.8	0.6	8	0.3	0.04	0.12	√	√
KLM1S100-8	c	8	50	1	1.8	0.6	8	0.3	0.04	0.12	√	
KLM1S150	d	6	50	1.5	3	1	8	0.5	0.007	0.08	√	√
KLM1S150-8	d	8	50	1.5	3	1	8	0.5	0.007	0.08	√	
KLM1S175	e	6	50	1.75	3.5	1	8	0.6	0.005	0.06	√	√
KLM1S175-8	e	8	50	1.75	3.5	1	8	0.6	0.005	0.06	√	
KLM1S200	f	6	50	2	4	1	8	1	0.003	0.045	√	√
KLM2S075	<u>A</u>	6	50	0.75	1.5	0.6	8	0.2	0.040	0.160	√	√
KLM2S075-12	<u>A</u>	12	50	0.75	1.5	1.2	8	0.2	0.040	0.160	√	√
KLM2S110	<u>B</u>	6	50	1.1	1.8	0.6	8	0.3	0.030	0.130	√	√
KLM2S110-12	<u>B</u>	12	50	1.1	1.8	1.2	8	0.3	0.030	0.130	√	√
KLM2S150	<u>C</u>	6	50	1.5	3.0	0.6	8	0.5	0.015	0.065	√	√
KLM2S150-12	<u>C</u>	12	50	1.5	3.0	1.2	8	0.5	0.015	0.065	√	√
KLM2S175	<u>D</u>	6	50	1.75	3.5	0.6	8	0.6	0.005	0.055	√	√
KLM2S175-12	<u>D</u>	12	50	1.75	3.5	1.2	8	0.6	0.005	0.055	√	√
KLM2S200	E	6	50	2	4	1	8	1	0.005	0.045	√	√
KLM2S260	F	6	50	2.6	5	1	8	4	0.003	0.035	√	√
KLM2S300	K	6	50	3	6	1	8	5	0.003	0.03	√	√
KLM2S350	L	6	50	3.5	7	1.2	8	6	0.002	0.02	√	√
KLM2S400	N	6	50	4	9	1.2	20	2	0.001	0.016	√	√
KLM3S075	La	6	50	0.75	1.5	0.8	8	0.3	0.017	0.18	√	√
KLM3S075-12	La	12	50	0.75	1.5	1.2	8	0.3	0.017	0.18	√	√
KLM3S110	Lb	6	50	1.1	2.2	0.8	8	0.3	0.015	0.13	√	√
KLM3S110-12	Lb	12	50	1.1	2.2	1.2	8	0.3	0.015	0.13	√	√
KLM3S150	Lc	6	50	1.5	3	0.8	8	0.3	0.010	0.08	√	√
KLM3S150-12	Lc	12	50	1.5	3	1.2	8	0.3	0.010	0.08	√	√
KLM3S175	L3	6	50	1.75	3.5	0.8	8	0.4	0.005	0.045	√	√
KLM3S175-12	L3	12	50	1.75	3.5	1.2	8	0.4	0.005	0.045		
KLM3S200	L7	6	50	2	4	0.8	8	0.5	0.005	0.04	√	√
KLM3S200-12	L7	12	50	2	4	1.2	8	0.5	0.005	0.04	√	√

Note: UL&cUL File No: E138827 / TUV File No:R50311748

# Polymer PTC Resettable Fuse: KLM Series

## SMD Low Resistance Type



### ■ Electrical Characteristics at 23°C

Part No.	Marking	V <sub>max.</sub>	I <sub>max.</sub>	I <sub>hold</sub>	I <sub>trip</sub>	Pd (Max.)	Maximum Time to Trip		Resistance		Safety Approvals	
							Current (A)	Time (Sec.)	Initial Ri	Post Trip R1	UL/cUL	TUV
		(V <sub>dc</sub> )	(A)	(A)	(A)	(W)			Min. (Ω)	Max(Ω)		
KLM3S260	L8	6	50	2.6	5	0.8	8	4	0.003	0.03	√	√
KLM3S260-12	L8	12	50	2.6	5	1.2	8	4	0.003	0.03	√	√
KLM3S300	L9	6	50	3	6	0.8	8	4	0.003	0.026	√	√
KLM3S300-12	L9	12	50	3	6	1.5	8	4	0.003	0.026	√	√
KLM3S350	L1	6	50	3.5	7	0.8	8	5	0.003	0.018	√	√
KLM3S350-12	L1	12	50	3.5	7	1.5	8	5	0.003	0.018	√	
KLM3S380	L2	6	50	3.8	8	0.8	8	5	0.002	0.014	√	√
KLM3S380-12	L2	12	50	3.8	8	1.5	8	5	0.002	0.014	√	
KLM3S400	L5	6	50	4	8	0.8	20	2	0.001	0.014	√	√
KLM3S400-12	L5	12	50	4	8	1.5	20	2	0.001	0.014	√	
KLM3S450	L6	6	50	4.5	9	0.8	22	2	0.001	0.014	√	√
KLM3S450-12	L6	12	50	4.5	9	1.5	22	2	0.001	0.014	√	
KLM3S500	Le	6	50	5	10	0.8	25	2	0.001	0.013	√	√
KLM3S500-12	Le	12	50	5	10	1.5	25	2	0.001	0.013	√	
KLM3S550	Lf	6	50	5.5	11	0.8	27.5	2	0.001	0.013	√	√
KLM3S600	Lg	6	50	6	12	0.8	30	2	0.001	0.012	√	√
KLM4S175	LA	6	50	1.75	3.5	0.8	8.0	2.5	0.006	0.040	√	√
KLM4S175-12	LA	12	50	1.75	3.5	1.2	8.0	2.5	0.006	0.040	√	√
KLM4S200	LB	6	50	2	4	0.8	8.0	3	0.005	0.024	√	√
KLM4S200-12	LB	12	50	2	4	1.2	8.0	3	0.005	0.024	√	√
KLM4S260	LE	6	50	2.6	5	0.8	8.0	4	0.003	0.02	√	√
KLM4S260-12	LE	12	50	2.6	5	1.2	8.0	4	0.003	0.02	√	√
KLM4S300	LG	6	50	3	6	0.8	15.0	2	0.003	0.02	√	√
KLM4S300-12	LG	12	50	3	6	1.5	15.0	2	0.003	0.02	√	√
KLM4S350	LN	6	50	3.5	7	0.8	17.5	2	0.003	0.018	√	√
KLM4S350-12	LN	12	50	3.5	7	1.5	17.5	2	0.003	0.018	√	√
KLM4S380	LK	6	50	3.8	8	0.8	19.0	2	0.003	0.016	√	√
KLM4S380-12	LK	12	50	3.8	8	1.5	19.0	2	0.003	0.016	√	√
KLM4S400	LM	6	50	4	8	0.8	20.0	2	0.002	0.014	√	√
KLM4S400-12	LM	12	50	4	8	1.5	20.0	2	0.002	0.014		
KLM4S450	LP	6	50	4.5	9	0.8	22.5	2	0.002	0.014	√	√
KLM4S450-12	LP	12	50	4.5	9	1.5	22.5	2	0.002	0.014		

Note: UL&cUL File No.: E138827

TUV File No.: 50311748

# Polymer PTC Resettable Fuse: KLM Series

## SMD Low Resistance Type



### ■ Electrical Characteristics at 23°C

Part No.	Marking	Vmax.	Imax.	Ihold	Itrip	Pd (Max.)	Maximum Time to Trip		Resistance		Safety Approvals	
							Current (A)	Time (Sec.)	Initial Ri	Post Trip R1	UL/cUL	TUV
		(V <sub>dc</sub> )	(A)	(A)	(A)	(W)			Min. (Ω)	Max(Ω)		
KLM4S500	LQ	6	50	5	10	0.8	25	2	0.002	0.012	√	√
KLM4S500-12	LQ	12	50	5	10	1.5	25	2	0.002	0.012		
KLM4S550	LR	6	50	5.5	11	0.8	27.5	2	0.002	0.011	√	√
KLM4S600	LS	6	50	6	12	0.8	30	2	0.001	0.01	√	√
KLM4S650	LV	6	50	6.5	13	0.8	32.5	2	0.001	0.009	√	√
KLM4S700	LX	6	50	7	14	1	35	2	0.001	0.008	√	√
KLM4S750	LY	6	50	7.5	15	1	37.5	2	0.001	0.007	√	√
KLM5S190	L190	6	50	1.9	4.9	1	9.5	4.5	0.003	0.025	√	√
KLM5S190-12	L190	12	50	1.9	4.9	1.5	9.5	4.5	0.003	0.025	√	√
KLM5S260	L260	6	50	2.6	6	1	13	2	0.003	0.024	√	√
KLM5S260-12	L260	12	50	2.6	6	1.5	13	2	0.003	0.024		
KLM5S270	L270	6	50	2.7	6.2	1	13	2	0.003	0.023	√	√
KLM5S270-12	L270	12	50	2.7	6.2	1.5	13	2	0.003	0.023	√	√
KLM5S300	L300	6	50	3	6.2	1	8	5	0.003	0.021	√	√
KLM5S300-12	L300	12	50	3	6.2	2	8	5	0.003	0.021	√	√
KLM5S350	L350	6	50	3.5	8.1	1	8	5	0.003	0.02	√	√
KLM5S350-12	L350	12	50	3.5	8.1	2	8	5	0.003	0.02	√	√
KLM5S370	L370	6	50	3.7	9.1	1	18.5	2	0.003	0.018	√	√
KLM5S370-12	L370	12	50	3.7	9.1	2	18.5	2	0.003	0.018	√	√
KLM5S400	L400	6	50	4	8	1	20.0	2	0.003	0.017	√	√
KLM5S400-12	L400	12	50	4	8	2	20.0	2	0.003	0.017	√	
KLM5S450	L450	6	50	4.5	9	1	22.5	2	0.001	0.014	√	√
KLM5S450-12	L450	12	50	4.5	9	2	22.5	2	0.001	0.014	√	
KLM5S500	L500	6	50	5	10	1	25	2	0.001	0.013	√	√
KLM5S500-12	L500	12	50	5	10	2	25	2	0.001	0.013	√	
KLM5S550	L550	6	50	5.5	11	1	27.5	2	0.001	0.008	√	√
KLM5S600	L600	6	50	6	12	1	30	2	0.001	0.008	√	√
KLM5S650	L650	6	50	6.5	13	1	32.5	2	0.001	0.008	√	√
KLM5S700	L700	6	50	7	14	1	35	2	0.001	0.007	√	√
KLM5S750	L750	6	50	7.5	15	1	37.5	2	0.001	0.006	√	√

Note: UL&cUL File No.: E138827

TUV File No.: R50311748

# Polymer PTC Resettable Fuse: KLM Series

## SMD Low Resistance Type



### ■ KLM1S (0603) Series Ihold & Itrip Thermal Derating Curve

Derating Curve for KLM1S (0603) Series

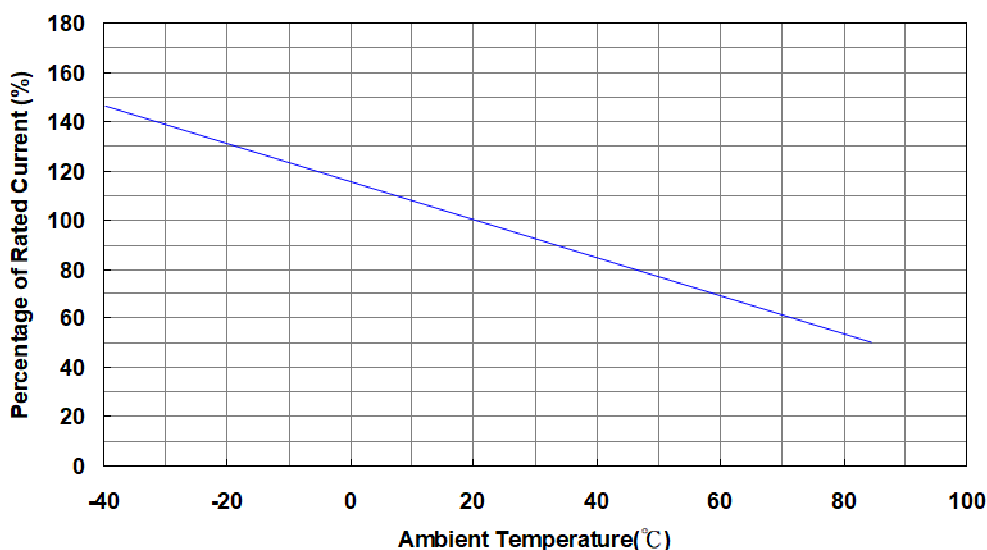

### ■ KLM1S (0603) Series Ihold Thermal Derating Chart

#### KLM1S (0603) Series

(Unit: A)

Part No.		Ambient Operation Temperature							
		-40°C	-20°C	0°C	23°C	40°C	60°C	70°C	85°C
KLM1S050	KLM1S050-8	0.81	0.71	0.62	<b>0.50</b>	0.42	0.30	0.24	0.16
KLM1S075	KLM1S075-8	1.24	1.07	0.94	<b>0.75</b>	0.62	0.47	0.37	0.21
KLM1S100	KLM1S100-8	1.36	1.25	1.10	<b>1.00</b>	0.83	0.65	0.52	0.33
KLM1S150	KLM1S150-8	2.37	2.07	1.80	<b>1.50</b>	1.25	0.93	0.74	0.50
KLM1S175	KLM1S175-8	2.57	2.23	1.99	<b>1.75</b>	1.49	1.24	1.00	0.80
KLM1S200		2.80	2.60	2.30	<b>2.00</b>	1.70	1.45	1.15	1.05

# Polymer PTC Resettable Fuse: KLM Series

## SMD Low Resistance Type



### ■ KLM2S (0805) Series Ihold & Itrip Thermal Derating Curve

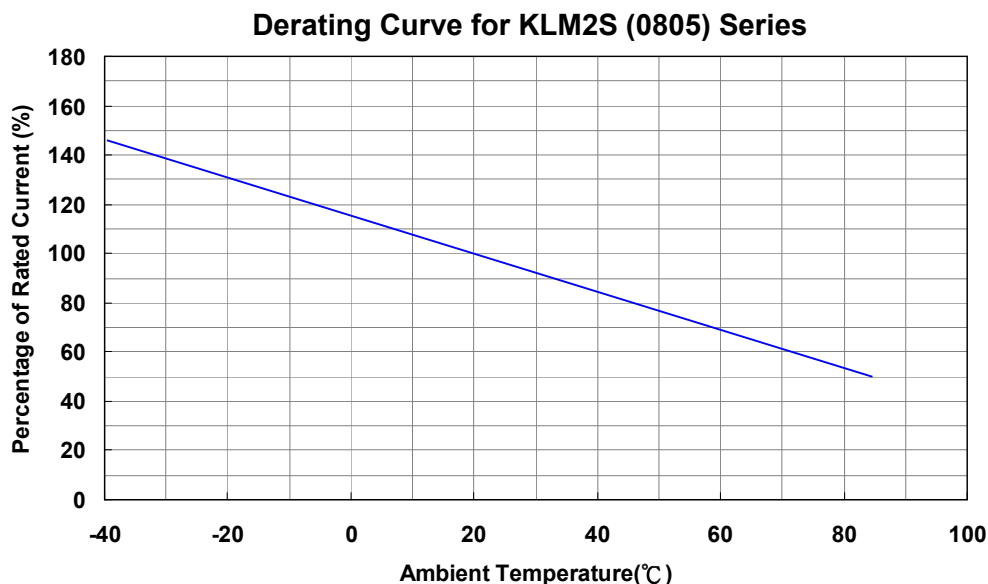

### ■ KLM2S (0805) Series Ihold Thermal Derating Chart

#### KLM2S (0805) Series

(Unit: A)

Part No.		Ambient Operation Temperature							
		-40°C	-20°C	0°C	23°C	40°C	60°C	70°C	85°C
KLM2S075	KLM2S075-12	1.24	1.07	0.94	<b>0.75</b>	0.62	0.47	0.37	0.21
KLM2S110	KLM2S110-12	1.93	1.65	1.38	<b>1.10</b>	0.83	0.55	0.41	0.23
KLM2S150	KLM2S150-12	2.37	2.07	1.80	<b>1.50</b>	1.25	0.93	0.74	0.50
KLM2S175	KLM2S175-12	2.57	2.33	2.07	<b>1.75</b>	1.49	1.24	1.00	0.91
KLM2S200		3.10	2.75	2.40	<b>2.00</b>	1.65	1.15	0.95	0.65
KLM2S260		3.80	3.30	2.80	<b>2.60</b>	2.20	1.78	1.55	1.05
KLM2S300		4.55	4.15	3.65	<b>3.00</b>	2.55	2.00	1.65	1.20
KLM2S350		5.6	4.38	3.81	<b>3.5</b>	2.74	2.28	1.93	1.37
KLM2S400		6.4	5	4.35	<b>4</b>	3.13	2.6	2.2	1.57



# Polymer PTC Resettable Fuse: KLM Series

## SMD Low Resistance Type



### ■ KLM3S (1206) Series Ihold & Itrip Thermal Derating Curve

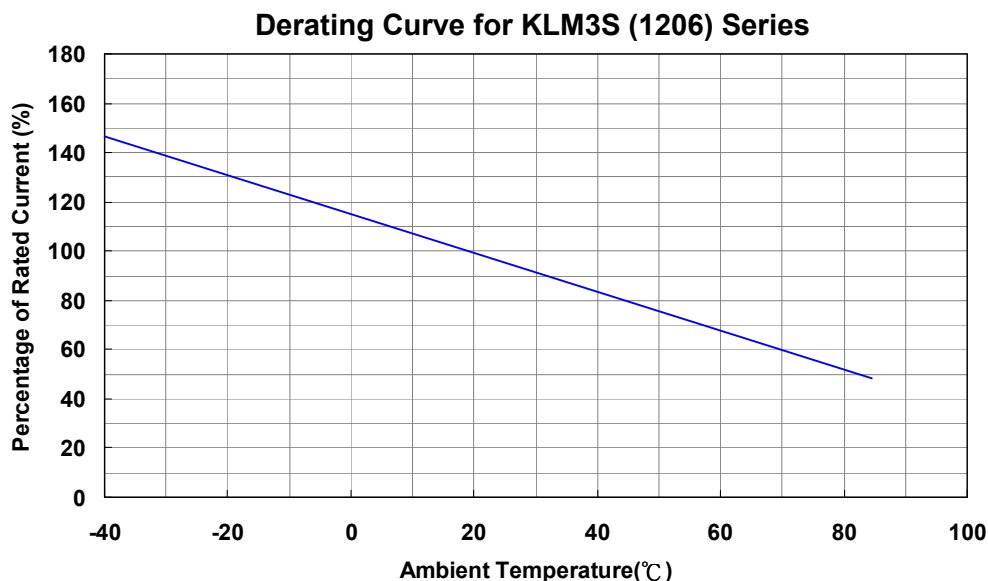

### ■ KLM3S (1206) Series Ihold Thermal Derating Chart

#### KLM3S (1206) Series

(Unit: A)

Part no		Ambient Operation Temperature							
		-40°C	-20°C	0°C	23°C	40°C	60°C	70°C	85°C
KLM3S075	KLM3S075-12	1.10	1.00	0.89	<b>0.75</b>	0.64	0.53	0.43	0.39
KLM3S110	KLM3S110-12	1.62	1.46	1.30	<b>1.10</b>	0.94	0.78	0.63	0.57
KLM3S150	KLM3S150-12	2.21	2.00	1.77	<b>1.50</b>	1.28	1.07	0.86	0.78
KLM3S175	KLM3S175-12	2.57	2.33	2.07	<b>1.75</b>	1.49	1.16	0.90	0.80
KLM3S200	KLM3S200-12	3.30	2.90	2.50	<b>2.00</b>	1.62	1.24	1.00	0.85
KLM3S260	KLM3S260-12	3.71	3.42	3.01	<b>2.60</b>	2.08	1.49	1.30	0.89
KLM3S300	KLM3S300-12	4.41	3.99	3.54	<b>3.00</b>	2.55	2.13	1.71	1.56
KLM3S350	KLM3S350-12	5.15	4.66	4.13	<b>3.50</b>	2.98	2.49	2.00	1.82
KLM3S380	KLM3S380-12	5.59	5.05	4.48	<b>3.80</b>	3.20	2.29	2.05	1.98
KLM3S400	KLM3S400-12	5.71	5.26	4.63	<b>4.00</b>	3.30	2.60	2.16	2.05
KLM3S450	KLM3S450-12	6.62	5.99	5.31	<b>4.50</b>	3.83	3.20	2.57	2.10
KLM3S500	KLM3S500-12	7.20	6.60	5.80	<b>5.00</b>	4.25	3.40	3.00	2.34
KLM3S550		8.00	7.15	6.35	<b>5.50</b>	4.90	4.10	3.70	3.05
KLM3S600		8.65	7.80	7.00	<b>6.00</b>	5.30	4.50	4.05	3.40

# Polymer PTC Resettable Fuse: KLM Series

## SMD Low Resistance Type



### ■ KLM4S (1210) Series Ihold & Itrip Thermal Derating Curve

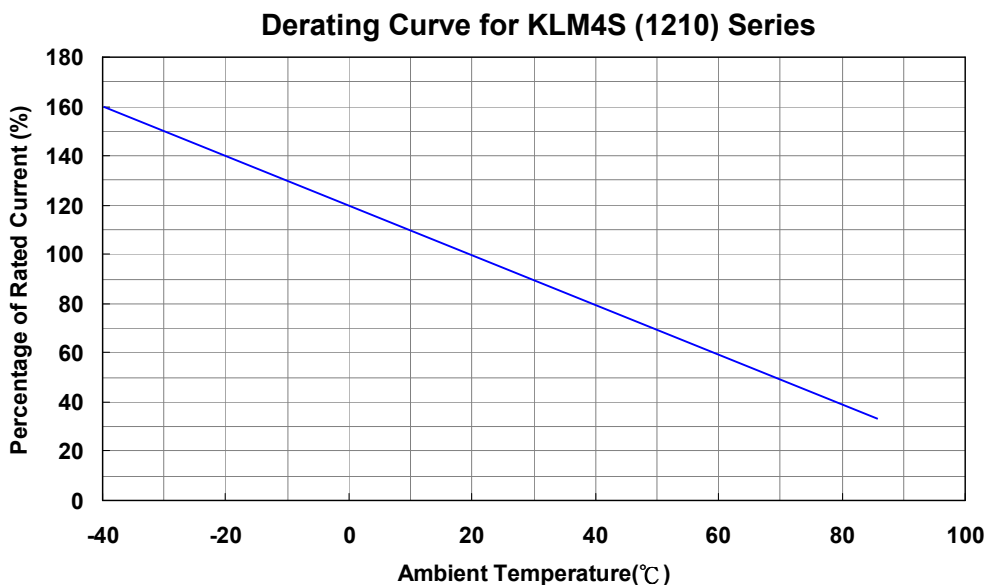

### ■ KLM4S (1210) Series Ihold Thermal Derating Chart

#### KLM4S (1210) Series

(Unit: A)

Part no		Ambient Operation Temperature							
		-40°C	-20°C	0°C	23°C	40°C	60°C	70°C	85°C
KLM4S175	KLM4S175-12	2.57	2.33	2.07	<b>1.75</b>	1.49	1.24	1.00	0.78
KLM4S200	KLM4S200-12	3.26	2.87	2.50	<b>2.00</b>	1.70	1.29	1.09	0.91
KLM4S260	KLM4S260-12	3.82	3.46	3.07	<b>2.60</b>	2.21	1.85	1.48	1.35
KLM4S300	KLM4S300-12	4.41	3.99	3.54	<b>3.00</b>	2.55	2.00	1.71	1.40
KLM4S350	KLM4S350-12	5.00	4.60	4.05	<b>3.50</b>	2.80	2.13	1.60	1.50
KLM4S380	KLM4S380-12	5.71	5.26	4.52	<b>3.80</b>	3.15	2.29	2.00	1.60
KLM4S400	KLM4S400-12	6.00	5.28	4.63	<b>4.00</b>	3.20	2.39	2.09	1.73
KLM4S450	KLM4S450-12	6.62	5.99	5.31	<b>4.50</b>	3.83	3.20	2.57	2.34
KLM4S500	KLM4S500-12	7.30	6.60	5.65	<b>5.00</b>	4.27	3.50	3.00	2.55
KLM4S550		8.00	7.15	6.35	<b>5.50</b>	4.90	4.10	3.70	3.05
KLM4S600		8.65	7.80	7.00	<b>6.00</b>	5.30	4.50	4.05	3.40
KLM4S650		9.15	8.15	7.40	<b>6.50</b>	5.50	4.90	3.60	2.70
KLM4S700		9.85	8.80	7.95	<b>7.00</b>	5.95	5.30	3.90	2.90
KLM4S750		10.25	9.15	8.45	<b>7.50</b>	6.75	6.15	4.70	3.65

# Polymer PTC Resettable Fuse: KLM Series

## SMD Low Resistance Type



### ■ KLM5S (1812) Series Ihold & Itrip Thermal Derating Curve

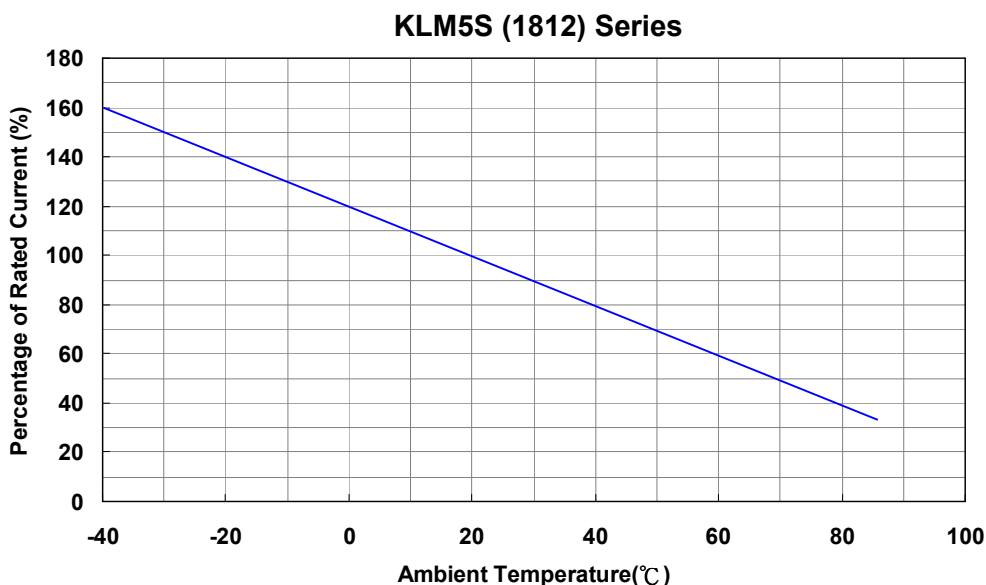

### ■ KLM5S (1812) Series Ihold Thermal Derating Chart

#### KLM5S (1812) Series

(Unit: A)

Part no		Ambient Operation Temperature							
		-40°C	-20°C	0°C	23°C	40°C	60°C	70°C	85°C
KLM5S190	KLM5S190-12	3.00	2.58	2.22	<b>1.90</b>	1.49	1.14	0.93	0.61
KLM5S260	KLM5S260-12	3.82	3.46	3.07	<b>2.60</b>	2.16	1.54	1.48	0.93
KLM5S270	KLM5S270-12	3.86	3.55	3.12	<b>2.70</b>	2.21	1.85	1.35	1.03
KLM5S300	KLM5S300-12	4.41	3.99	3.54	<b>3.00</b>	2.55	2.10	1.71	1.12
KLM5S350	KLM5S350-12	5.43	4.73	4.13	<b>3.50</b>	2.80	2.13	1.75	1.56
KLM5S370	KLM5S370-12	5.44	4.92	4.37	<b>3.70</b>	3.15	2.63	2.11	1.92
KLM5S400	KLM5S400-12	5.88	5.28	4.64	<b>4.00</b>	3.41	2.84	2.55	2.08
KLM5S450	KLM5S450-12	6.62	5.99	5.31	<b>4.50</b>	3.83	3.20	2.57	2.34
KLM5S500	KLM5S500-12	7.35	6.60	5.85	<b>5.00</b>	4.31	3.55	3.15	2.55
KLM5S550		8.12	7.32	6.40	<b>5.50</b>	4.85	3.88	3.40	2.55
KLM5S600		8.88	8.00	6.99	<b>6.00</b>	5.15	5.00	3.45	2.60
KLM5S650		9.65	8.66	7.58	<b>6.50</b>	5.55	4.50	3.65	2.75
KLM5S700		10.62	9.30	8.15	<b>7.00</b>	5.98	5.05	3.95	3.00
KLM5S750		11.35	9.95	8.70	<b>7.50</b>	6.75	5.75	4.95	3.55

# Polymer PTC Resettable Fuse: KLM Series

## SMD Low Resistance Type



### Recommended Soldering Condition

#### IR-Reflow Soldering Profile

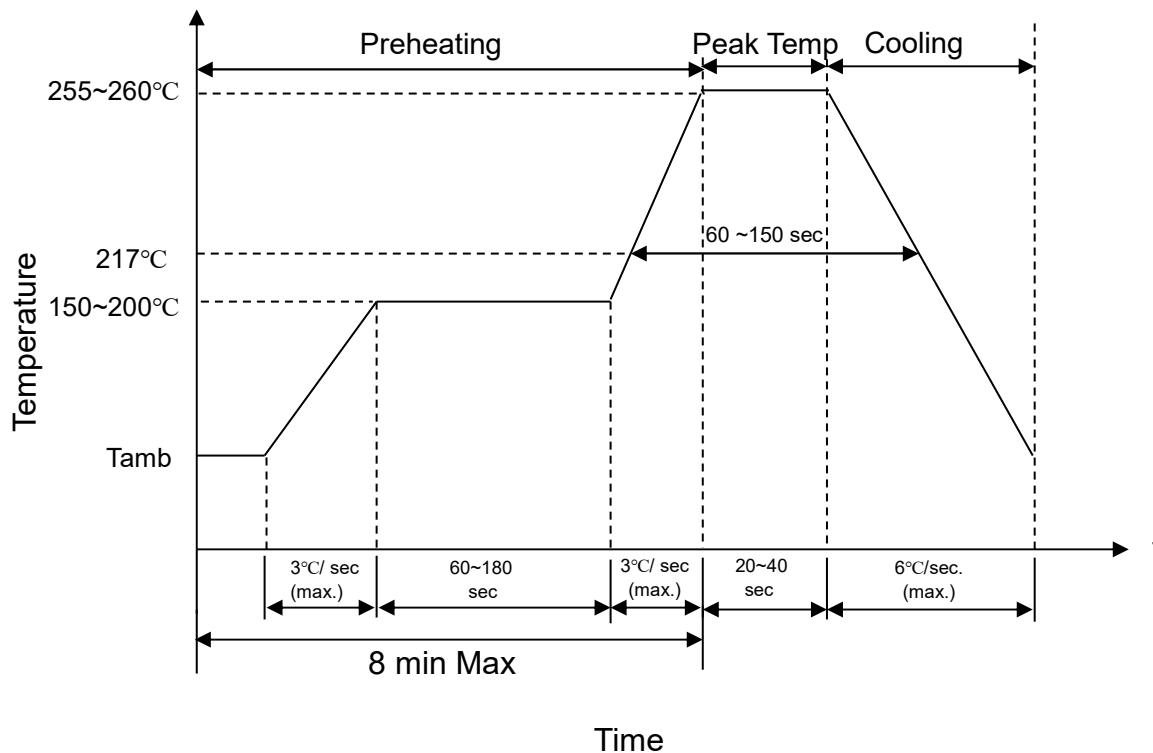

- Welding method of the product is reflow welding, and wave soldering is not recommended.
- Recommended reflow methods: IR, vapor phase, and hot air oven.
- Devices can be cleaned by using standard industry methods and solvents.

#### Note:

- If reflow temperature exceeds the recommended profile, devices may not meet the performance requirements.
- Devices are not designed to be wave soldered to the bottom side of the board.

### Recommended Soldering Pad Dimensions (Nominal)

(Unit: mm)

Series	Size	A	B	C
KLM1S	0603	0.8	1.00	1.00
KLM2S	0805	1.20	1.00	1.50
KLM3S	1206	2.00	1.00	1.90
KLM4S	1210	2.00	1.00	2.80
KLM5S	1812	3.45	1.78	3.50

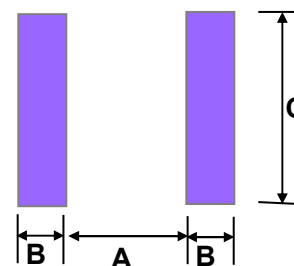

# Polymer PTC Resettable Fuse: KLM Series

## SMD Low Resistance Type



### ■ Reliability

Item	Standard	Test Condition / Methods	Criteria
Passive Aging	IEC 60738-1	85±5°C, 1000±24hrs	±10% typical resistance change
Humidity Aging	Specification Standard	85±5°C, 80~85%RH, 100±5hrs	±15% typical resistance change
Rapid Change of Temperature	IEC 60738-1	85±5/-40±5°C, 20 cycles Duration:30min	-30% typical resistance change
Overload and Endurance Test	UL 1434	Vmax, 120% Imax, 50 cycles Vmax, 300% Itrip, 6000 cycles	No visible damage
Aging Test	UL 1434	Vmax, Itrip ≤ I ≤ Imax, 1000±24hrs	No visible damage
Solderability	IEC 60068-2-58	245 ± 5°C, 3 ± 0.3sec	At least 95% of terminal electrode is covered by new solder.
Resistance to Soldering Heat	IEC 60068-2-58	260 ± 5°C, 10 ± 1sec	Rf<R1, No visible damage

### ■ Package

#### ● Taping Specification

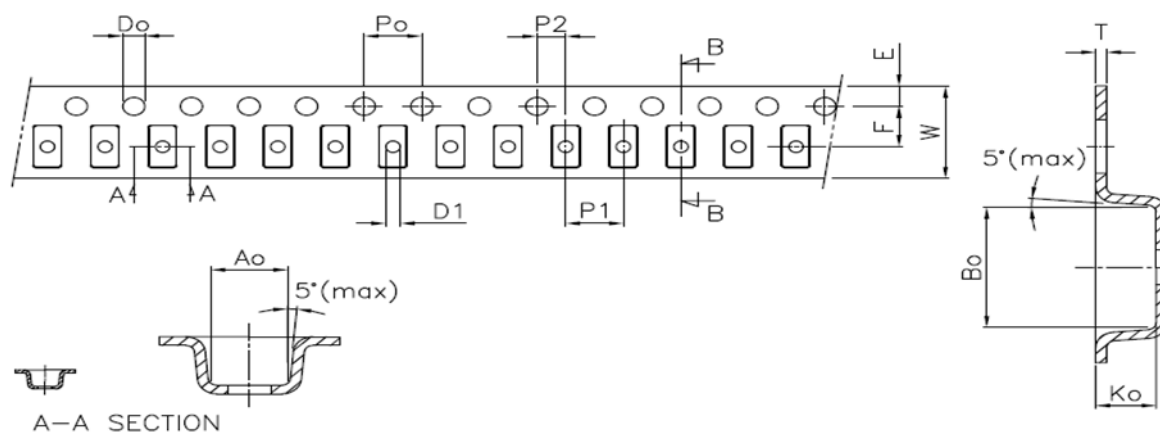

#### ◆ KLM1S Series: SMD 0603 Type

For KLM1S050 ~ KLM1S100

(Unit: mm)

Index Size	A <sub>0</sub>	B <sub>0</sub>	K <sub>0</sub>	P <sub>0</sub>	P <sub>1</sub>	P <sub>2</sub>	T	E	F	D <sub>0</sub>	D <sub>1</sub>	W	10P <sub>0</sub>
0603	±0.05	±0.05	±0.05	±0.10	±0.10	±0.05	±0.05	±0.10	±0.05	+0.10 -0	+0.10 -0.05	+0.30 -0.10	±0.20
0603	1.1	1.85	0.60	4.0	4.0	2.0	0.20	1.75	3.5	1.5	0.5	8.0	40.0

For KLM1S150 ~ KLM1S200

(Unit: mm)

Index Size	A <sub>0</sub>	B <sub>0</sub>	K <sub>0</sub>	P <sub>0</sub>	P <sub>1</sub>	P <sub>2</sub>	T	E	F	D <sub>0</sub>	D <sub>1</sub>	W	10P <sub>0</sub>
0603	±0.10	±0.15	±0.05	±0.10	±0.10	±0.05	+0.05 -0.08	±0.10	±0.05	±0.05	Min.	±0.20	±0.20
0603	1.1	1.85	0.75	4.0	4.0	2.0	0.23	1.75	3.5	1.55	0.4	8.0	40.0

# Polymer PTC Resettable Fuse: KLM Series

## SMD Low Resistance Type



### ◆ KLM2S Series: SMD 0805 Type

(Unit: mm)

Index Size	A <sub>0</sub>	B <sub>0</sub>	K <sub>0</sub>	P <sub>0</sub>	P <sub>1</sub>	P <sub>2</sub>	T	E	F	D <sub>0</sub>	D <sub>1</sub>	W	10P <sub>0</sub>
	±0.10	±0.10	±0.050	±0.08	±0.10	±0.05	±0.10	±0.10	±0.05	±0.05	Min.	±0.10	±0.20
0805	1.6	2.3	0.9	4.0	4.0	2.0	0.25	1.75	3.50	1.55	1.0	8.0	40.0

### ◆ KLM3S Series: SMD 1206 Type

For KLM3S075~KLM3S150

(Unit: mm)

Index Size	A <sub>0</sub>	B <sub>0</sub>	K <sub>0</sub>	P <sub>0</sub>	P <sub>1</sub>	P <sub>2</sub>	T	E	F	D <sub>0</sub>	D <sub>1</sub>	W	10P <sub>0</sub>
	±0.10	±0.10	±0.05	±0.10	±0.10	±0.10	±0.05	±0.10	±0.10	±0.05	Min.	±0.30	±0.20
1206	1.85	3.45	0.85	4.0	4.0	2.0	0.23	1.75	3.5	1.55	1.0	8.0	40.0

For KLM3S175~ KLM3S600

(Unit: mm)

Index Size	A <sub>0</sub>	B <sub>0</sub>	K <sub>0</sub>	P <sub>0</sub>	P <sub>1</sub>	P <sub>2</sub>	T	E	F	D <sub>0</sub>	D <sub>1</sub>	W	10P <sub>0</sub>
	±0.10	±0.10	±0.05	±0.10	±0.10	±0.10	±0.05	±0.10	±0.10	±0.05	Min.	±0.30	±0.20
1206	1.95	3.55	1.4	4.0	4.0	2.0	0.23	1.75	3.5	1.55	1.0	8.0	40.0

### ◆ KLM4S Series: SMD 1210 Type

(Unit: mm)

Index Size	A <sub>0</sub>	B <sub>0</sub>	K <sub>0</sub>	P <sub>0</sub>	P <sub>1</sub>	P <sub>2</sub>	T	E	F	D <sub>0</sub>	D <sub>1</sub>	W	10P <sub>0</sub>
	±0.10	±0.10	±0.05	±0.10	±0.10	±0.10	±0.05	±0.10	±0.10	±0.05	Min.	±0.30	±0.20
1210	2.82	3.63	1.47	4.0	4.0	2.0	0.23	1.75	3.5	1.55	1.0	8.0	40.0

### ◆ KLM5S Series: SMD 1812 Type

For KLM5S190~ KLM5S400

(Unit: mm)

Index Size	A <sub>0</sub>	B <sub>0</sub>	K <sub>0</sub>	P <sub>0</sub>	P <sub>1</sub>	P <sub>2</sub>	T	E	F	D <sub>0</sub>	D <sub>1</sub>	W	10P <sub>0</sub>
	±0.10	±0.10	±0.05	±0.10	±0.10	±0.10	±0.03	±0.10	±0.10	±0.05	Min.	±0.30	±0.20
1812	3.50	5.0	0.9	4.0	8.0	2.0	0.25	1.75	5.5	1.55	1.50	12.0	40.0

For KLM5S450~ KLM5S750

(Unit: mm)

Index Size	A <sub>0</sub>	B <sub>0</sub>	K <sub>0</sub>	P <sub>0</sub>	P <sub>1</sub>	P <sub>2</sub>	T	E	F	D <sub>0</sub>	D <sub>1</sub>	W	10P <sub>0</sub>
	±0.10	±0.10	±0.05	±0.10	±0.10	±0.10	±0.05	±0.10	±0.10	±0.05	Min.	±0.30	±0.20
1812	3.56	4.94	1.7	4.0	8.0	2.0	0.25	1.75	5.5	1.55	1.50	12.0	40.0

# Polymer PTC Resettable Fuse: KLM Series

## SMD Low Resistance Type



### Quantity

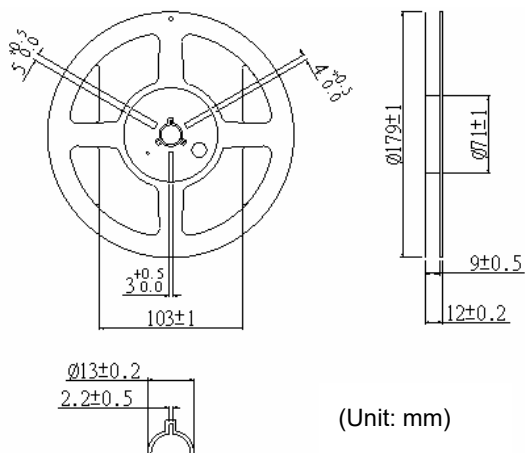

Size	Part no	Quantity (pcs/reel)	Carton Size (mm)	Quantity (reel/carton)
0603	KLM1S050~100	6,000	350*350*290	28
	KLM1S150~200	5,000		
0805	KLM2S	4,000		
1206	KLM3S075~150	5,000		
	KLM3S175~600	2,500		
1210	KLM4S	3,000		

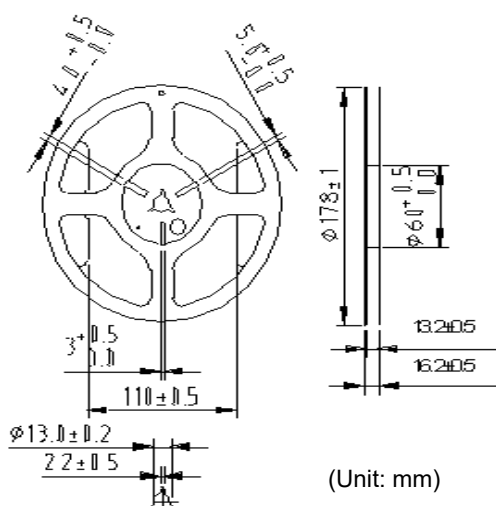

Size	Part no	Quantity (pcs/reel)	Carton Size (mm)	Quantity (reel/carton)
1812	KLM5S190~400	2,000	350*350*290	24
	KLM5S450~750	1,000		

### Warehouse Storage Conditions of Products

- Storage Conditions:
  - Storage Temperature: -10 °C ~+ 40 °C
  - Relative humidity: ≤ 75%RH
  - Thermistors must be kept away from sunlight and stored in a non-corrosive atmosphere.
- Period of Storage: 1 year